

## ARA, the chair



The neutrality of the shapes allows this chair to live among other objects, to be integrated in any typology of space, indoor or outdoor and to remain a seductive and elegant object.



**STACKABLE &  
LIGHTWEIGHT**



The handle gives character to the chair and it makes the lifting and moving easier.

## ARA, the armchair

IN&OUT



Thanks for the tapered shapes of the legs, this armchair appears lightweight and elegant, although resistant and non-deformable. The upper part of back structure forms a big handle that gives a distinct character and at the same time it represents an interesting functional element for an easy lifting and moving.



100%  
RECYCLABLE



## JORGE PENSI, the designer



**JORGE PENSI DESIGN STUDIO**

Born in Buenos Aires in 1946, he studies Architecture in his home town. When he graduates in 1971 he has already begun designing furniture as a partner of an interior design business.

In 1975 he leaves Argentina, acquires Spanish citizenship and in 1977 settles in Barcelona. Together with designer Alberto Liévore and theorists Norberto Chaves and Oriol Pibernat he sets up the "Berenguer Group".

In 1984, Jorge Pensi opens his own design office. He works for international companies as designer and architect. From 1993 he takes up teaching.

## ARA, technical sheet

### THE CHAIR

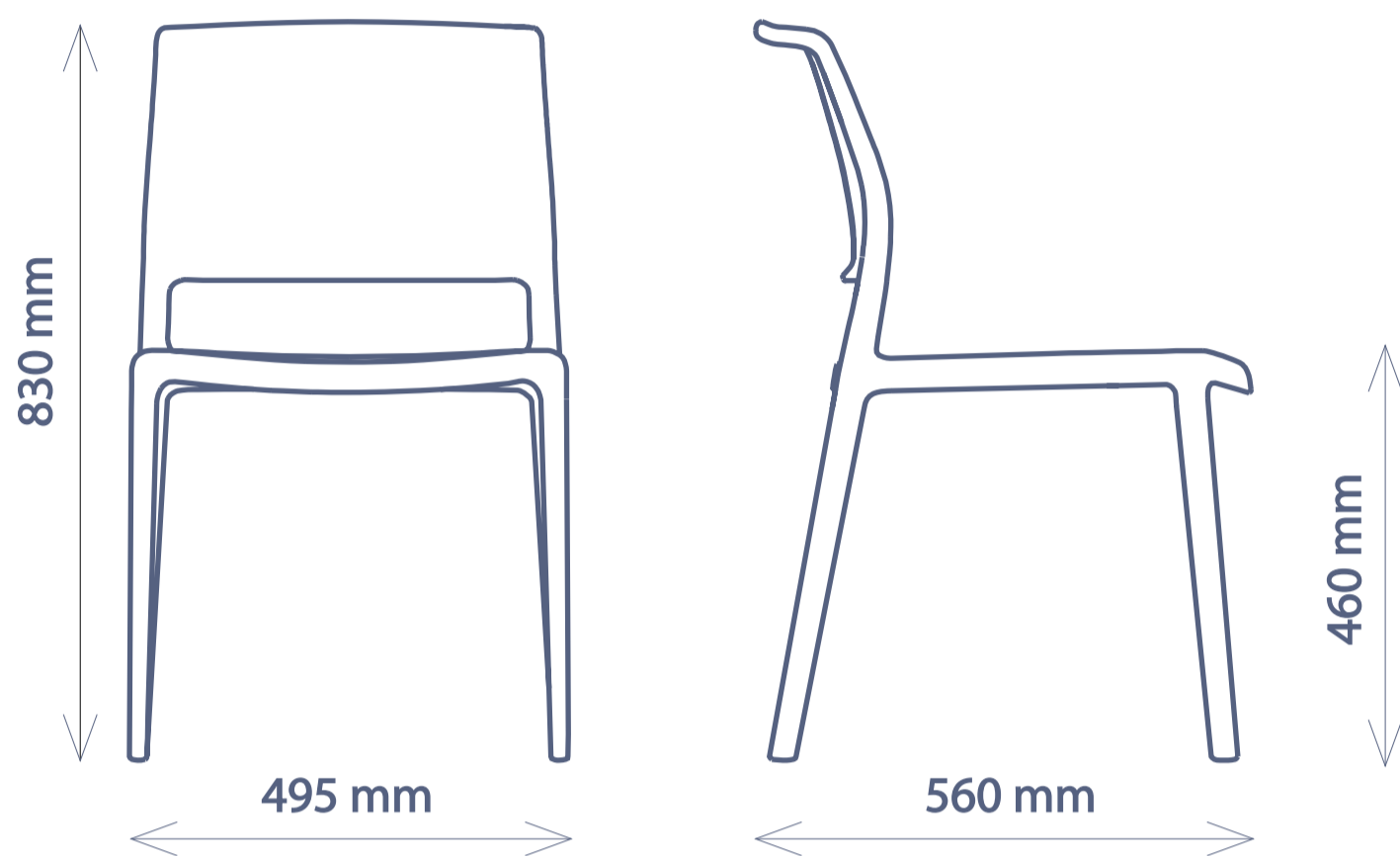

Weight: 4,2 Kg  
4 Pz - MC 0,47  
Packing: 4 Pz

ARA CHAIR is available in the following colours:



### THE ARMCHAIR

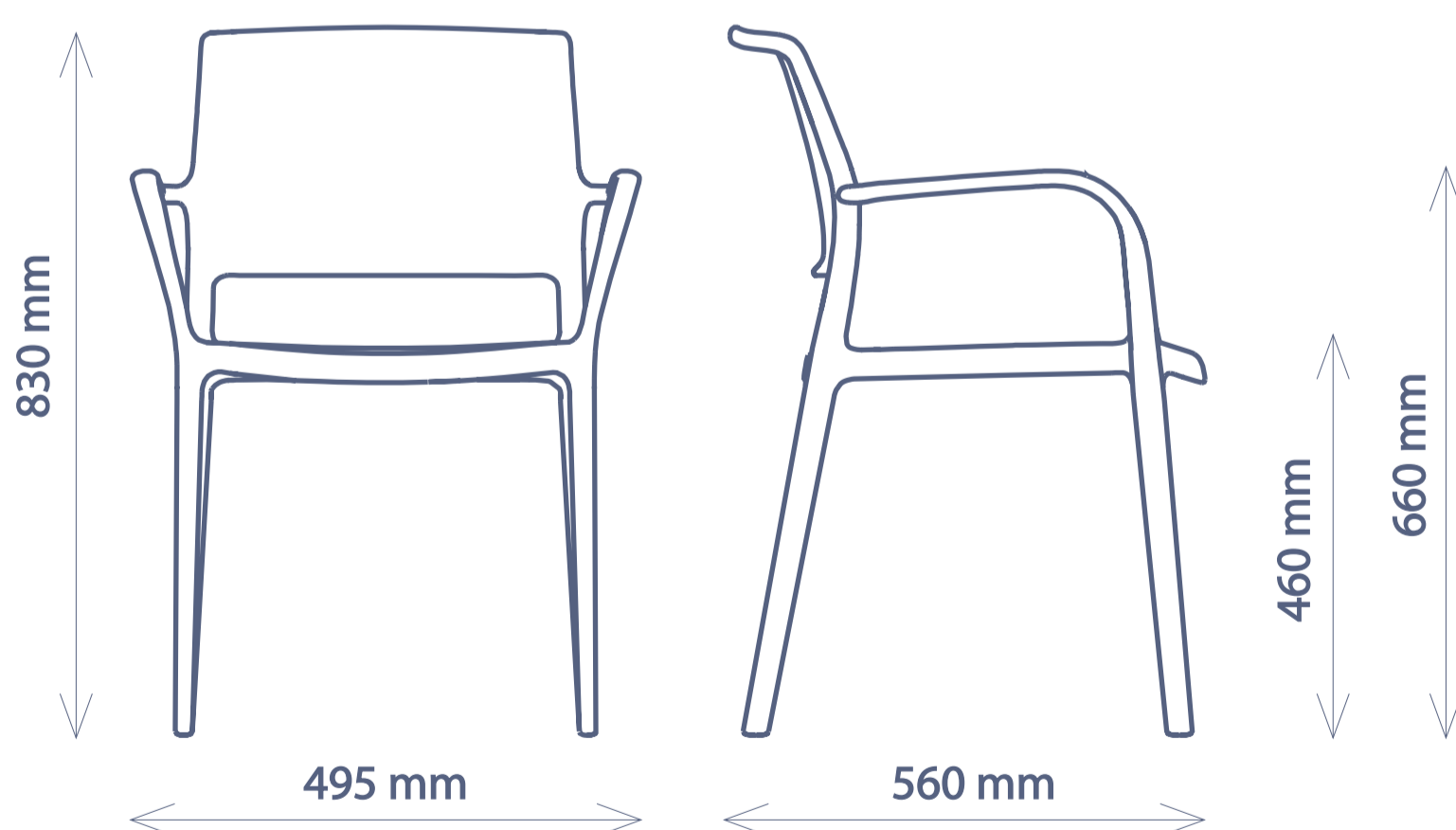

Weight: 4,8 Kg  
4 Pz - MC 0,47  
Packing: 4 Pz

ARA ARMCHAIR is available in the following colours:



**PEDRALI®**



**PEDRALI®**



**PEDRALI®**

